

SPD Control Systems Corporation (SCSC)

Changing the way you view windows®

TintMaker

Automotive 8-Window SPD Controller (TintMaker/After-Market)

User Guide

Version 2.0
October 25, 2010

SPD Control Systems Corporation
CEWIT / Stony Brook University R&D Park
1500 Stony Brook Road
Stony Brook, NY 11794-6040
www.spdControlSystems.com
info@spdControlSystems.com

Copyright SPD Control Systems Corp © 2010

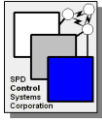
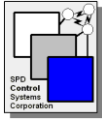

Table of Contents

1	OVERVIEW	4
2	CONTROLLER PACKAGE.....	5
3	TINTMAKER/AFTER-MARKET DESCRIPTION.....	6
3.1	OPERATIONAL MODES	6
3.2	TINTMAKER/AFTER-MARKET FUNCTIONS.....	7
3.1.1	Power Up	7
3.1.2	LEDs – Status Indications.....	8
3.1.3	Safety Features.....	9
3.1.4	Watchdog Timer.....	9
4.	TINTMAKER/AFTER-MARKET CONFIGURATION AND SETUP	10
5	TINTMAKER/AFTER-MARKET INSTALLATION.....	13
5.1	CONNECT WINDOWS	13
5.2	CONNECT CONTROL SWITCH TO CONTROL PORT	14
5.3	CONNECT 12 VDC POWER SUPPLY TO POWER CABLE/SERIAL CABLE	14
5.4	SERIAL PORT CONNECTION	14
6	SUPPORT	15
7.	TROUBLESHOOTING.....	16
8.	WARRANTY	17
	APPENDIX A - PIN ASSIGNMENT TABLE FOR INPUT CONTROL CONNECTOR (DB-25)	18
	APPENDIX B - PIN ASSIGNMENT TABLE FOR POWER CABLE AND SERIAL PORT CONNECTOR	19
	APPENDIX C - WIRING OF WINDOW POWER OUTPUT CABLE	19
	APPENDIX D - SCHEMATIC FOR CONTROL SWITCHES AND POTENTIOMETERS.....	19
	APPENDIX E – SPECIFICATIONS	21
	APPENDIX F – COMMAND INTERFACE SPECIFICATION	23
F.1	INTRODUCTION.....	23
F.2	COMMUNICATIONS INTERFACE.....	23
F.3	COMMAND SET.....	23
F.3.1	AT WA Command	24
F.3.2	AT I Command.....	24
F.3.3	AT SC Command	25
F.3.4	AT P Command	25
F.3.5	AT D Command	25
F.3.6	AT S Command.....	26
F.3.7	AT T Command.....	26
F.3.8	AT V Command	27
	APPENDIX G – CURRENT ADDTI VALUES SUPPORTED (SEE AT,A COMMAND) DEFINITION	28
	APPENDIX H – DISPLAY/DEMO CONFIGURATION.....	29



References

1. SCSC Support Web Site - <http://www.spdcontrolsystems.com/support-TintMaker.htm>

Abbreviations

A/D	Analog-to-Digital
EMI	Electromagnetic Interference
EO Table	Electro-Optical Table: This table holds the characteristics of different versions of SPD film. The tables allow for the uniform control of the level of light transmittance.
ESD	Electrostatic Discharge
TintMaker/After-Market	TintMaker Automotive Dynamic Window Controller After-Market 8-Window Controller
SPD	Suspended Particle Device
SCSC	SPD Control Systems Corporation
TintMaker®	SCSC Trademark of its Dynamic Window Controller line

Document History

Version 1.0	February 23, 2010	Initial Release
Version 1.1	August 23, 2010	Added Demo/Display Configuration (Appendix H) Added Warranty (Section 8)
Version 2.0	October 25, 2010	Minor updates

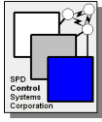

TintMaker/After-Market 8-Window Controller User Guide

1 Overview

This document is the **User Guide for the TintMaker Automotive After-Market 8-Window SPD Controller (TintMaker/After-Market)**. The document contains the information required to configure, install and troubleshoot the controller.

The basic functionality of the TintMaker/After-Market is to change multiple panes of SPD Glass to specific levels of window transparency in an automotive environment. The TintMaker/After-Market can control up to 8 SPD windows independently. The controller accepts control inputs which can be used to operate one window or all windows. The inputs can be any type of passive control devices such as switches or potentiometers or sensors.

WARNING

The TintMaker/After-Market Controller is capable of delivering a high voltage electric current which can be fatal. Please use caution in the handling and wiring of the TintMaker/After-Market at all times. Be sure to make all connections to windows secure before applying power to the unit.



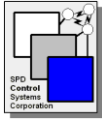

2 Controller Package

The TintMaker/After-Market includes,

- TintMaker/After-Market Controller
- DC power and serial cable
- Window Power Cable
- User Guide (this document) – also available on the SCSC website – see below

The TintMaker/After-Market is intended for the automotive after-market.

The following diagram shows an overview of the basic connections for the unit.

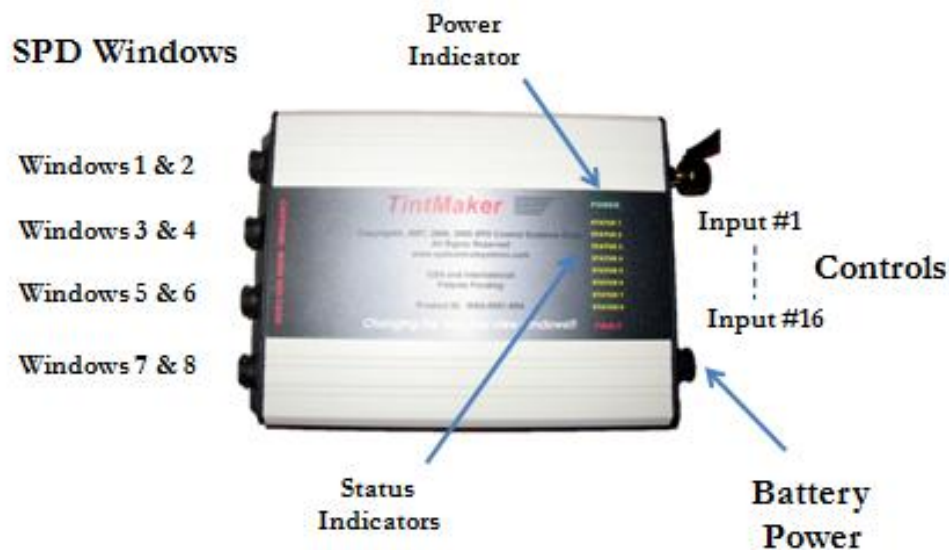
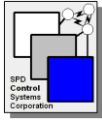

Figure 1.0 - Basic Wiring Connections of the TintMaker/After-Market



3 TintMaker/After-Market Description

3.1 Operational Modes

The TintMaker/After-Market is a software-driven electronic controller. This permits a great deal of flexibility in operating and customizing the controller. The operating modes include:

- Manual
- Automatic
- Demonstration
- External Interface Control

Manual Mode - Switches

There are 16 A/D (analog/digital) ports or inputs on the TintMaker/After-Market that can be used for switches and sensors to control the tint level of the SPD windows. A wide variety of switches and sensors can be supported. A single switch / sensor may control an individual window or all windows.

In manual mode the switches connected to the A/D inputs allow for the tinting of the SPD windows. The tint can be adjusted from dark to clear and any state in between. There are three basic types of switches supported by the TintMaker/After-Market:

- ON/OFF Switch (Dark or Clear)
- Potentiometer (Variable Tint)
- Push Button (8 Levels of Tint)

The On/Off switch selects either fully dark or fully clear settings.

The potentiometer (rheostat) allows for a continuous adjustment of the tint of a connected SPD window.

The push button allows for the setting of the tint level of a connected SPD window to one of 8 different levels. Each push of the button increases the tint of the SPD window by 12.5 percent. Once the window has reached the fully dark state the next push of the button will decrease the tint by 12.5 percent. This cycle is repeated.

The default configuration of the TintMaker/After-Market is setup to allow control of individual SPD windows with any of these three different types of controls. The unit is also configured to control all 8 windows from a single control input. In general the odd numbered control inputs are configured to accept a push button/momentary contact switch and the even numbered input are configured to accept either a potentiometer/variable resistor or a simple on/off switch/ See Appendix A which shows the default configuration of the control inputs.

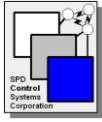

TintMaker/After-Market 8-Window Controller User Guide

See the schematic diagrams in Appendix D for the wiring of the push button, potentiometer and on/off switch controls.

Please note that the operation of a window which is controlled by more than one switch may be unpredictable. For example, if a window is configured to be controlled by both a push button and a potentiometer the two switches may interact in unexpected ways. The control logic is designed so that the last control to change a window state will be in control until another control is changed.

Automatic Mode - Sensors

Different types of sensors may be attached to one or more A/D ports. Sensors, like photo sensors and occupancy sensors, allow for the automatic operation of the windows depending on how you want the windows to dynamically respond to sensor readings.

The current release of the controller does not support sensor input other than sensor which behave like the switch types mentioned above.

Demo Mode

Demo mode automatically cycles the attached windows (1 to 8) through clear and dark settings with each window offset in time or out of phase from the other. See the Configuration Switches section for directions to set Demo Mode.

External Interface

The TintMaker/After-Market accepts external commands via its serial communications port. All aspects of the controller can be operated via the command interface. This includes initialization, configuration of A/D ports, error reporting, status checking, diagnostics, and changing the tint of individual windows.

The command interface specification is provided in Appendix I.

3.2 TintMaker/After-Market Functions

3.1.1 *Power Up*

When power is connected the TintMaker/After-Market runs a startup diagnostic. It then reads the configuration switches to determine how many windows are connected. The TintMaker/After-Market reports any problems via the LEDs. See the Section 7, Troubleshooting below.

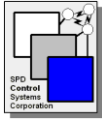

TintMaker/After-Market 8-Window Controller User Guide

3.1.2 LEDs – Status Indications

The LEDs are located on the top of the controller.



The 10 LEDs are labeled as follows:

- **POWER**
- **STATUS 1 to STATUS 8**
- **FAULT**

POWER LED (Green)

This LED is on while the system is running. The LED turns on 500 milliseconds after power is applied.

STATUS LEDs (Yellow)

There is one LED per window. The LED responds as follows,

- 1 LED blinks if a window fault is detected. (Blink rate is 500ms on, 500ms off)
- 2 LED will blink when a window with an open circuit is attempted to be turned on. (Blink rate: 100ms on, 900ms off)

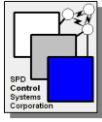

FAULT LED (Red)

This LED displays the following error conditions:

- 1 A fault on any of the 8 window leads will cause this LED to blink. (Blink Rate: 500ms on, 500ms off)
- 2 An attempt to turn on a channel for a window with an open circuit will cause the LED to blink. (Blink Rate: 1000ms on, 1000ms off).
- 3 A diagnostic error will cause the LED to stay on. (Turned on without blinking)

3.1.3 Safety Features

The TintMaker/After-Market provides the following safety features,

- **Over current** - This feature automatically shuts down a window channel in the event of a change in connection which causes an increase in the current drawn from the controller.
- **Short detection** - This feature automatically shuts down the window channel in the event of a short circuit on the connection to the window.
- **Open circuit** – This feature automatically shuts down the window channel if there is not a complete circuit connecting the window.

3.1.4 Watchdog Timer

The watchdog timer monitors the health of the software and hardware of the controller and generates a system reset in the event of a failure.

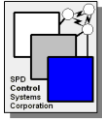

TintMaker/After-Market 8-Window Controller User Guide

4. TintMaker/After-Market Configuration and Setup

The TintMaker/After-Market allows for multiple configuration settings using DIP switches located inside the case on the main PCB board. These include:

- Number of windows connected: 1-8
- Selection of Electro-Optical (EO) Table: 1-16
This table holds the characteristics of different versions of SPD film. The tables allow for the uniform control of the level of light transmittance.
- Mode Selection: Demonstration Mode or Manual Mode

The default configuration settings are:

- 2 windows configured
- EO table for Hitachi film samples from April 2008, (0.44 % to 52 % light transmittance)
- Manual mode. The unit is also pre-configured to allow the push button and potentiometer to control the tint of the first two windows 1 and 2 respectively.

Opening the Case

The TintMaker/After-Market arrives pre-configured to operate 2 windows using Hitachi April 2008 film. In order to change the configuration settings it is necessary to open the TintMaker/After-Market casing. The following steps should be followed:

1. Remove the two black screws on either side of the communications panel of the TintMaker/After-Market. This is the right side panel that contains a DB-25 connector labeled **INPUT CONTROLS**, a round, 8-pin conductor, connector label **POWER** and a threaded connector labeled **ANTENNA**.

NOTE: The Antenna connection is not used in the Automotive After-Market Controller. Wireless connectivity to other TintMaker controllers to form controller networks is used in other applications.



Location of Screws

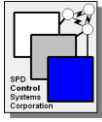

TintMaker/After-Market 8-Window Controller User Guide

2. Remove the four black plastic nuts on the left side panel which hold the window output connectors labeled **GLASS 1 GLASS 2, GLASS 3 GLASS 4**, etc. See picture below.



3. Carefully pull the right side panel away from the casing. The main PCB board will slide out. Pull out the circuit board until the configuration switches are easily accessible. Be careful not to unseat the LED board. See illustration.

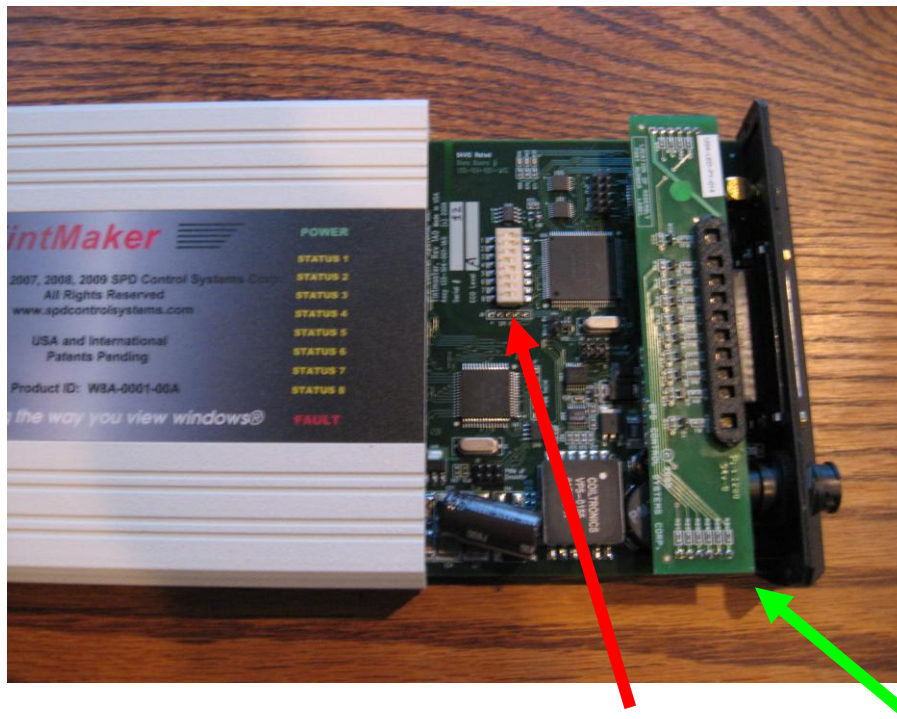

Location of Configuration Switches

LED Board

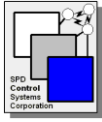

Enlarged View of Configuration Switches



Changing the Configuration Switches

Window Selection - This setting selects the number of SPD windows connected to the controller.

Number of Windows	Switch 1	Switch 2	Switch 3
1	ON	ON	ON
2	OFF	ON	ON
3	ON	OFF	ON
4	OFF	OFF	ON
5	ON	ON	OFF
6	OFF	ON	OFF
7	ON	OFF	OFF
8	OFF	OFF	OFF

EO Table Selection - This setting selects the correct Electro-Optical table for the type of SPD glass connected to the controller. Note that only 3 EO tables are currently loaded into the controller.

EO Table	4	5	6	7
DIC 2006	ON	ON	ON	ON
Hitachi 2007	OFF	ON	ON	ON
Hitachi April 2008	ON	OFF	ON	ON

Demo Mode Selection - Demo Mode provides for the automatic operation of all configured SPD windows. The TintMaker/After-Market software cycles through an automated script which changes the tint of the windows from full clear, to half clear to dark. The timing of each window is offset in order to generate a random overall effect.

Switch # 8: OFF DEMO MODE ,
 ON MANUAL MODE

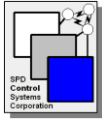

Reassembling the Unit

Reassemble the unit by sliding the processor board back into the casing. **Please note that the LED board which sits above the main processor board (see diagram above) needs to be guided into the top most slots on the casing in order for the main processor board to slide back into the casing.**

Replace the two black screws that hold the right side panel to the casing.

Replace the four plastic nuts which hold the window output connectors on the left side panel.

5 TintMaker/After-Market Installation

Once the TintMaker/After-Market has been configured it can then be connected to windows, switches, and power.

5.1 Connect Windows

The window power cable supplied with the controller contains 4 conductors. The cable can be used to connect two SPD windows. Plug the window power output cable into the connector labeled GLASS 1 GLASS 2 on the TintMaker/After-Market and connect the wire pairs (BLACK/RED for GLASS 1 and GREEN/WHITE for GLASS 2) to two SPD windows or film samples. (See Appendix C for the wiring of the Power Output Cable.)



Figure 2 - Picture of the Power Output Cable

More SPD windows can be connected to the TintMaker/After-Market by assembling more cables. See Appendix C for the pin outs and connector specification. Please note that the configuration switches need to be set for the number of SPD windows connected to the unit.

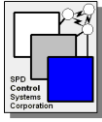

5.2 Connect Control Switch to Control Port

Control switches or potentiometers should be wired to a male 25-pin DB-25 connector which is plugged into the **INPUT CONTROLS** connector on the end panel of the TintMaker/After-Market. Refer to Appendix D for the wiring of these switches. Refer to Appendix F for the configuration commands which may be needed to change the settings of the A/D control inputs to conform to the type of switches used.

5.3 Connect 12 VDC power supply to power cable/serial cable.

The controller is provided with a cable that contains connections for both the 12 Volt DC power supply and the command interface serial port.

Connect the black and red wires of the power cable to a 12 volt DC power supply. The power supply should be able to provide up 10 amperes of current continuously. It is recommended that the TintMaker/After-Market be protected with an automotive type fuse of 15 amps, 12 VDC.

NOTE: If the TintMaker/After-Market is wired to an accessory circuit of the vehicle the unit may not operate when the vehicle is not running.

NOTE: Be careful in connecting the polarity of the DC power supply to the TintMaker controller insuring that the positive and negative are connected to the correct pins.

5.4 Serial Port Connection

The serial port and power utilize the same connector. A cable with battery wires and a serial wire with connector is included with the controller.



Serial Port and Power Connector

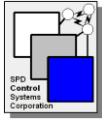

TintMaker/After-Market 8-Window Controller User Guide

6 Support

The TintMaker support tools include documents, web site, Email and Skype.

We are always interested in your comments and feedback. Please send your comments to: support@spdControlSystems.com.

Web Site	Support Information TintMaker/After-Market User Guide (This Document) TintMaker Web Page TintMaker Brochure
Email (see Note)	support@spdControlSystems.com
Telephone	631-866-6063
Skype: Text & Voice (see Note)	<ol style="list-style-type: none"> 1. Email support@spdControlSystems.com requesting Skype Chat or Telephone session. Wait for a reply. 2. Skype Address: SCSC.support
Evaluation Comments (see Note)	Email: support@spdControlSystems.com Please provide details about your test setup. See Note below.

Note: When contacting SCSC support please provide the following information,

- Your name, company, Email address and phone number. If you have a Skype address please include it.
- The serial number of the controller you are testing.
- Describe your test setup: number of windows connected, approx. size of each window, switches and port connections, power source, test environment and anything else about your environment you may think may be useful.
- Describe the problem. Is it repeatable? Is there a direct cause of the problem? Has the controller worked previously without this problem occurring?

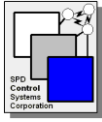

7. Troubleshooting

This section provides possible solutions to common problems encountered with the controller.

<p>Windows Do Not Change Tint?</p>	<p>Check if controller is powered on. The Power LED should be On. Check that the window cable attached to the controller in the correct position. Check if the cable is firmly seated in the connector. Check if the window is working by using a different working controller. Check if the switch for the window is in the correct position. Put the controller in Demonstration Mode and check if the window is working. If it is, then replace switch. With the switch cable delivered with the unit v1.0 - the switches are on A/D ports 1 and 3.</p>
<p>Error Fault LED is ON</p>	<p>A fault on any of the 8 window leads will cause this LED to blink. (Blink Rate: 500ms on, 500ms off). Check window connections.</p> <p>An attempt to turn on a channel for a window with an open circuit will cause the LED to blink. (Blink Rate: 1000ms on, 1000ms off) Check window connections.</p> <p>A Diagnostic Error will cause the LED to stay on. (Turned on without blinking). Contact SCSC support.</p>
<p>Fault LED Is Blinking</p>	<p>Each Fault LED corresponds to a single window.</p> <p>LED blinks if a window fault is detected. (Blink rate is 500ms on, 500ms off). Check window connection.</p> <p>LED will blink when a window with an open circuit is attempted to be turned on. (Blink rate: 100ms on, 900ms off) Check window connection.</p>
<p>Controller Resets (powers off and then on)</p>	<p>The controller's watchdog timer monitors the health of the software and hardware of the controller and generates a system reset in the event of a failure. Contact SCSC Support if this problem continues.</p>

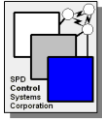

TintMaker/After-Market 8-Window Controller User Guide

8. Warranty

TintMaker One-Year Limited Warranty

This Warranty is provided by SPD Control Systems Corporation, Center for Wireless & Info. Tech., Stony Brook Univ. R&D Park, 1500 Stony Brook Road Stony Brook, NY 11794-6040, for the TintMaker SPD Controller (the "Device").

We warrant the Device against defects in materials and workmanship under ordinary consumer use for one year from the date of original retail purchase. During this warranty period, if a defect arises in the Device, and you follow the instructions for returning the Device, we will, at our option and to the extent permitted by law, either (i) repair the Device using either new or refurbished parts, (ii) replace the Device with a new or refurbished Device, or (iii) refund to you all or part of the purchase price of the Device.

This limited warranty applies to any repair, replacement part or replacement Device for the remainder of the original warranty period or for ninety days, whichever period is longer. All replaced parts and Devices for which a refund is given shall become our property. This limited warranty applies only to hardware components of the Device that are not subject to accident, misuse, neglect, fire or other external causes, alterations, repair, or commercial use.

Instructions. Please contact Support (US **631-866-6063** or support@spdControlSystems.com) for specific instructions about how to obtain warranty service for your Device..

In general, you will need to deliver your Device in either its original packaging or in equally protective packaging to,

SPD Control Systems Corporation
CEWIT / SBU R&D Park
1500 Stony Brook Road
Stony Brook, NY 11794-6040

Limitations. TO THE EXTENT PERMITTED BY LAW, THE WARRANTY AND REMEDIES SET FORTH ABOVE ARE EXCLUSIVE AND IN LIEU OF ALL OTHER WARRANTIES AND REMEDIES, AND WE SPECIFICALLY DISCLAIM ALL STATUTORY OR IMPLIED WARRANTIES, INCLUDING, BUT NOT LIMITED TO, WARRANTIES OF MERCHANTABILITY, FITNESS FOR A PARTICULAR PURPOSE AND AGAINST HIDDEN OR LATENT DEFECTS. IF WE CANNOT LAWFULLY DISCLAIM STATUTORY OR IMPLIED WARRANTIES, THEN TO THE EXTENT PERMITTED BY LAW, ALL SUCH WARRANTIES SHALL BE LIMITED IN DURATION TO THE DURATION OF THIS EXPRESS LIMITED WARRANTY AND TO REPAIR OR REPLACEMENT SERVICE AS DETERMINED BY US IN OUR SOLE DISCRETION. SOME JURISDICTIONS DO NOT ALLOW LIMITATIONS ON HOW LONG A STATUTORY OR IMPLIED WARRANTY LASTS, SO THE ABOVE LIMITATION MAY NOT APPLY TO YOU.

WE ARE NOT RESPONSIBLE FOR DIRECT, SPECIAL, INCIDENTAL OR CONSEQUENTIAL DAMAGES RESULTING FROM ANY BREACH OF WARRANTY OR UNDER ANY OTHER LEGAL THEORY. IN SOME JURISDICTIONS THE FOREGOING LIMITATION DOES NOT APPLY TO DEATH OR PERSONAL INJURY CLAIMS, OR ANY STATUTORY LIABILITY FOR INTENTIONAL AND GROSS NEGLIGENT ACTS AND/OR OMISSIONS, SO THE ABOVE EXCLUSION OR LIMITATION MAY NOT APPLY TO YOU. SOME JURISDICTIONS DO NOT ALLOW THE EXCLUSION OR LIMITATION OF DIRECT, INCIDENTAL OR CONSEQUENTIAL DAMAGES, SO THE ABOVE EXCLUSION OR LIMITATION MAY NOT APPLY TO YOU.

This limited warranty gives you specific legal rights. You may have additional rights which vary from jurisdiction to jurisdiction and this limited warranty does not affect those rights.

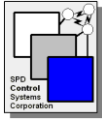

TintMaker/After-Market 8-Window Controller User Guide

Appendix A - PIN Assignment Table for Input Control Connector (DB-25)

Pin Number	Signal	Description	Assigned Window	Default Control Type	
1	ADIN_8B	Control Input A/D #16	ALL	Potentiometer or ON/OFF	
2	GND	Ground			
3	ADIN_7A	Control Input A/D #13	GLASS 7	Push Button	
4	ADIN_6B	Control Input A/D #12	GLASS 6	Potentiometer or ON/OFF	
5	GND	Ground			
6	ADIN_5A	Control Input A/D #9	GLASS 5	Push Button	
7	ADIN_4B	Control Input A/D #8	GLASS 4	Potentiometer or ON/OFF	
8	GND	Ground			
9	ADIN_3A	Control Input A/D #5	GLASS 3	Push Button	
10	ADIN_2B	Control Input A/D #4	GLASS 2	Potentiometer or ON/OFF	
11	GND	Ground			
12	ADIN_1A	Control Input A/D #1	GLASS 1	Push Button	
13	+5 VDC	+5 volts DC			
14	ADIN_8A	Control Input A/D #15	ALL	Push Button	
15	ADIN_7B	Control Input A/D #14	GLASS	Potentiometer or ON/OFF	
16	+5 VDC	+5 volts DC			
17	ADIN_6A	Control Input A/D #11		Push Button	
18	ADIN_5B	Control Input A/D #10		Potentiometer or ON/OFF	
19	+5 VDC	+5 volts DC			
20	ADIN_4A	Control Input A/D #7		Push Button	
21	ADIN_3B	Control Input A/D #6		Potentiometer or ON/OFF	
22	+5 VDC	+5 volts DC			
23	ADIN_2A	Control Input A/D #3		Push Button	
24	ADIN_1B	Control Input A/D #2		Potentiometer or ON/OFF	
25	+5 VDC	+5 volts DC			

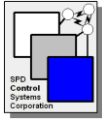

Appendix B - Pin Assignment Table for power cable and serial port connector

Pin Number	Signal
1	Receive Data
2	Transmit Data
3	+ 12 VDC
4	Serial Communications Ground
5	Power Ground
6	No Connection
7	No Connection
8	No Connection

Appendix C - Wiring of Window Power Output Cable

Pin Number	Signal
1	Odd numbered Window
2	Odd numbered Window
3	Even Numbered Window
4	Even Numbered Window

Appendix D - Schematic for Control Switches and Potentiometers

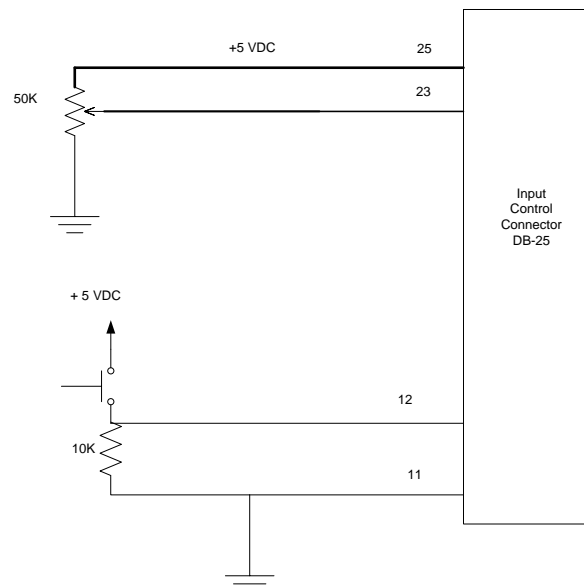

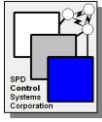

TintMaker/After-Market 8-Window Controller User Guide

Diagram for wiring of an ON/OFF switch for use with the DWC-102 SPD window controller

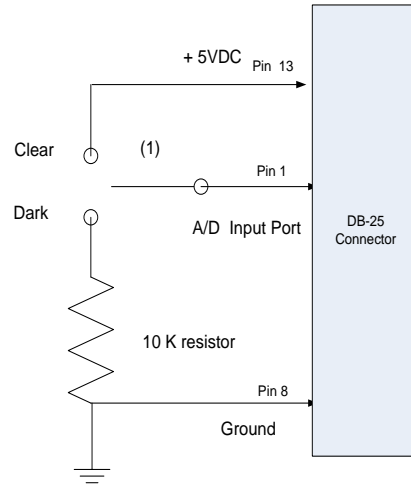

(1) The switch should be an SPDT (Single Pole Double Throw) type switch. It should not have a center OFF position.

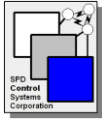

TintMaker/After-Market 8-Window Controller User Guide

Appendix E – Specifications

The following specifications are for the controller and are subject to change based on internal SCSC enhancements.

	Description	Comment
General		
<i>Microprocessor</i>	Freescle HCS12 Family	
<i>Software Environment</i>	Proprietary Real-time Scheduler	
<i>Customizable Software Applications</i>	yes	
<i>Customizable Hardware</i>	yes	
<i>Power-up Diagnostics</i>	yes	
<i>Status Check/Diagnostic Command Set</i>	yes	
Film Characteristics		
<i>Normalize Tint Level</i>	yes	Supports all SPD film types / characteristics. Provides linear tint control of SPD film regardless its electrical non-linearity.
<i>Max. Number of Windows</i>	8	
<i>Max. Size Film for Each Window</i>	16 sq. ft (1.2 M ²)	
<i>Output voltage</i>	30 – 125VAC RMS	
<i>Output Isolation</i>	yes	AC output electrically isolated from the vehicle power source
<i>Maximum Output Current</i>	30 mA per window	
<i>SPD Film Output Frequency</i>	30Hz to 200Hz	60 Hz is used by the controller. There may be film produced requiring a higher frequency and there are special cases where a higher or lower frequency may be desirable.
<i>Window Tint Transition Time</i>	1 to 2 seconds for 95% of change	
Power		
<i>DC</i>	12 VDC	Will tolerate short duration power variations between 7.5 and 17 VDC
<i>Max Power Consumption</i>	48 Watts	All 8 windows in the clear state.
<i>Backup power</i>	optional battery	

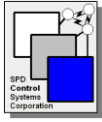

TintMaker/After-Market 8-Window Controller User Guide

Communication Bus		
<i>RS-232C</i>	yes	
<i>LIN</i>	optional	
<i>CAN</i>	optional	
<i>Other</i>	Most other comms protocols can be supported	

Safety Features		
<i>Over Current Auto Shutdown</i>	yes	
<i>Ground Fault Auto Shutdown</i>	yes	

Physical Characteristics		
<i>Enclosed controller</i>	8.0" (W) x 5.25" (D) x 1.25" H 20.3 cm (W) x 13.3 cm (D) x 3.2 cm (H)	Dimensions include mounting flanges
<i>Weight</i>	1.5 lb (0.68 Kg.)	
<i>Temperature Range</i>	-40°C to 120°C	
<i>Connectors</i>	<p>4 Switchcraft EN3 right-angle, weather-tight connectors are used for the window output signals</p> <p>Conec Waterproof connectors are used for the command interface port and the control switch input connector</p> <p>1 Switchcraft EN3P8M weather tight connector for the power and serial port connections.</p>	
<i>Control Switch/Sensor Inputs</i>	16	Supports push buttons, variable controls or sensors. A switch / sensor may be assigned to a single window, a group of windows, or all windows.
<i>EMI and ESD</i>	tbd	
<i>Enclosure</i>	Extruded aluminum enclosure with integral mounting flanges	

Auto Application		
<i>Auto Location</i>	Normally mounted in the trunk and wires run to each of the windows it controls.	

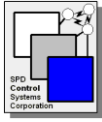

Appendix F – Command Interface Specification

F.1 Introduction

This section describes the command set and the communications interface to be supported by the SCSC TintMaker 8-window automotive controller. The TintMaker controller can be fully operated through the onboard communications port. The commands are:

- **AT WA** Change tinting to an absolute percentage value
- **AT I** Initialize an A/D port, Window or the Controller
- **AT SC** Set 8-Window Controller Date and/or Time
- **AT P** Poll A/D for input
- **AT D** Dump A/D data, Error log, Diagnostic Data, other saved data
- **AT S** Stop the Dumping Data
- **AT T** Run Diagnostics and return status.
- **AT V** Display current version of Firmware

The communications port of the controller is programmed via a simple modem-like AT command set. An ASCII printable string of commands and parameters is sent from a host computer program, or a computer running a terminal emulation package such as HyperTerminal in order to operate various features of the controller.

A demonstration of basic controller functions, such as changing the tinting of window #7 to 40% clear, can be done by manually typing commands from a terminal into the communications port. More complex testing, to show all windows changing simultaneously or all 16 Analog to Digital Converters (ADCs) reading data while windows are changing, can be driven through a host computer connecting to the communications port and running a pre-programmed script. There are many variants of HyperTerm that support such scripting languages.

F.2 Communications Interface

The communications interface on the TintMaker controller is based on the RS2-32C standard. The port operates at 38.4KBPS. The byte framing is one start bit and one stop bit.

F.3 Command Set

This section lists the commands that are to be supported over the communications port

- **AT WA** Change tinting to an absolute percentage value
- **AT I** Initialize an A/D port, Window or the Controller
- **AT SC** Set 8-Window Controller Date and/or Time
- **AT P** Poll A/D for input
- **AT D** Dump A/D data, Error log, Diagnostic Data, other saved data

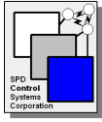

- **AT S** Stop the Dumping Data
- **AT T** Run Diagnostics and return status.
- **AT V** Display current version of firmware

After a command is executed, there are two possible results that may be returned to the host sending the command:

- | | | |
|-------|---|---|
| OK | - | The command executed properly. |
| ERROR | - | The command is improperly formatted or the specified command is not supported . |

F.3.1 AT WA Command

Format: AT WA,<Window Number>,<Percentage Tinting>

- Where:
- Window Number is a value between 1 and 8
 - Percentage Tinting is a value between 0 (clear) and 100 (dark)

This absolute tint level command sets the specified window number to the specified level of tinting.

F.3.2 AT I Command

Format: AT I,<A | C>

- Where:
- 'A' specifies initialization of an A/D port
 - 'C' specifies initialization of the Controller

The full format of the command depends upon which form of initialization has been specified.

AT I,A,<A/D Number>,<ADDTI Number>,<poll time>,<optional parameter>

- Where:
- A/D Number is a value between 1 and 16
 - ADDTI Number is the A/D Device Type Identifier, a unique number that specifies how the A/D data is supposed to be interpreted by the controller. When ADDTI = 0 the A/D port is disabled. See Appendix J for the list of ADDTI values currently supported.
 - Poll time is a 16 bit value which defines how often the port is polled. The number is in tenths of a second, e.g. 10 = 1 second.
 - An optional parameter value used during the initialization of the A/D for a particular ADDTI value. This is a hexadecimal value between 0x0 and 0xffff.

AT I,C,<Ramp Rate>

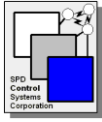

Where:

- Ramp Rate is the speed at which window tinting is changed by a AT WR command. The value specifies the percentage (0 to 100) increase or decrease in tinting that will be changed in 1 second of time.

The AT I, C command is not implemented in the current version of the controller.

F.3.3 AT SC Command

Format: AT SC,<MM:DD:YY>,<HH:MM:SS>

This command is used to set the date and/or time on the controller. Either the month, day, year field or the hour, minute, second field may be left off by leaving the field out. If the month, day, year field is not used, the command is of the form: AT SC,.,<HH:MM:SS>.

F.3.4 AT P Command

Format: AT P,<A/D Number>

Where: - A/D Number is a value between 1 and 16

This command will read the specified A/D number and return its current value in the format:

A/D#: <value>

This information may appear before or after the OK response from the command execution.

F.3.5 AT D Command

Format: AT D,<A | E | D | ...>

The Dump data command is used to output data from the controller to the communications port. The data being dumped will begin after the OK response is generated. The individual command selected may have parameters associated with it.

AT D,A,<A/D Number>

Where <A/D Number> is a value between 1 and 16

The AT D,A command will read the specified A/D and display the current value. It continually polls the A/D at the poll rate defined by the ADDTI entry number specified during A/D initialization. The format of the data generated is the same as the AT P command output. The data will continue to be output to the comm port until an AT S command is sent to the communications port or any other AT command.

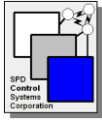

The AT D,E command will dump any accumulated error log data being stored in the 8-Window controller.

The AT D,D command will dump any accumulated diagnostic data that is stored in the 8-Window controller.

F.3.6 AT S Command

Format: AT S

The AT S command will stop any data dump that is in progress.

F.3.7 AT T Command

Format: AT T, < M | C | A | D >

The AT T command will run board level diagnostic tests and return a completion status for the test.
Example:

For the Demo Mode/Cycling Test the controller will step through the full range of tint levels for all of the configured windows and continue to repeat the cycle. The controller should output a confirmation for each full cycle that is completed.

AT T,M - The memory test insures the correct operation of the RAM, EEPROM and Flash memory.

AT T,C - This test verifies that all windows configured by the DIP switches are connected to the controller.

AT T,A - This test is not currently implemented.

AT T, D – Demo Mode/Cycling Test - This test will step through the full range of tint levels for all configured windows and output a message for each completed cycle. The parameter to start and stop the demo mode is defined as:

AT T,D,<0/1> where 0 = stop demo mode and 1 = start demo mode.

Status messages for the AT T commands are defined as:

AT T,M - Memory Test	- Passed
AT T,C - Window Output Circuit Test	- Passed (For configured window connections)
AT T,A - A/D Test	- Passed
AT T,D - Demo Mode/Cycling Test	- Cycle Completed.

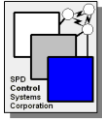

F.3.8 AT V Command

Format: AT V

The AT V command will display the current version of firmware running on the Tintmaker TintMaker/After-Market controller. Example:

Version 1.1
SPD Control Systems Corporation
Copyright 2007,2008,2009,2010

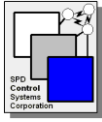

TintMaker/After-Market 8-Window Controller User Guide

Appendix G – Current ADDTI Values Supported (see AT,A command) Definition

<u>ADDTI Value</u>	<u>Device Type</u>	<u>Windows Controlled</u>	<u>Function</u>	<u>Notes</u>
1	Push Button	All windows	Changes the tint level of all windows by 12.5% per button press.	TintMaker A/D port 15 default value.
2	Rheostat or Slider Switch	All windows	Allows the direct setting of window tinting from 0% to 100% based on the entire range of the slider switch.	TintMaker port 16 default value.
3	Push Button	Operates a single window	Changes the tint level of the windows it controls by 12.5% per button press.	TintMaker default value. A/D Port 1 Controls Window 1. Port 3 – Window 2 Port 5 – Window 3 Port 7 – Window 4 Port 9 – Window 5 Port 11 – Window 6 Port 13 – Window 7
4	Rheostat or Slider Switch	Operates a single window	Allows the direct setting of window tinting from 0% to 100% based on the entire range of the slider switch.	TintMaker default value. A/D port 2 controls Window 1. Port 4 – Window 2 Port 6 – Window 3 Port 8 – Window 4 Port 10 – Window 5 Port 12 – Window 6 Port 14 – Window 7

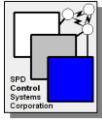

Appendix H – Display/Demo Configuration

The picture below shows how we mount the controller and power supply for display purposes.

The fixed voltage power supply we use is from Jameco Electronics, www.jameco.com, part # 123386, made by Meanwell, Model S-100F-12.

